

# DA026W

## ENGINEQUEST

(800) 426-8771

(702) 649-7776

(702) 649-6777 fax

www.enginequest.com



August 2001

### Opposite Side Dipstick Adaptors

convert pre-1980 Chevrolet Small Blocks to 1980 thru 1985

Tools Needed

- Tube of silicone • 17/64" drill bit • 13/64" drill bit
- 1/4- 28 tap • 1/4" drill • 3/8" die grinder

#### Follow these steps...

1. Place casting in position (centered on #4 Main Cap) and center first hole with 17/64" bit. Drill 1/16" deep.
2. Drill a 13/64" hole and tap with 1/4-28 tap.
3. Bolt casting to block with one of the screws provided. Drill and tap second hole using the same procedure as first hole.
4. Clean block and casting thoroughly. Apply RTV silicone liberally to casting. Bolt it to the block using both bolts and remove excess silicone.
5. Cut notch for dipstick tube clearance.

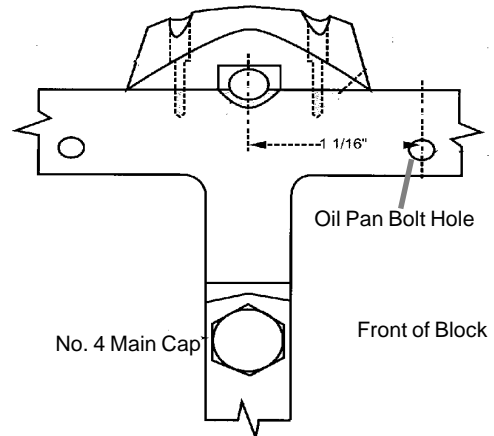

# DA026W

## ENGINEQUEST

(800) 426-8771

(702) 649-7776

(702) 649-6777 fax

www.enginequest.com



August 2001

### Opposite Side Dipstick Adaptors

convert pre-1980 Chevrolet Small Blocks to 1980 thru 1985

Tools Needed

- Tube of silicone • 17/64" drill bit • 13/64" drill bit
- 1/4- 28 tap • 1/4" drill • 3/8" die grinder

#### Follow these steps...

1. Place casting in position (centered on #4 Main Cap) and center first hole with 17/64" bit. Drill 1/16" deep.
2. Drill a 13/64" hole and tap with 1/4-28 tap.
3. Bolt casting to block with one of the screws provided. Drill and tap second hole using the same procedure as first hole.
4. Clean block and casting thoroughly. Apply RTV silicone liberally to casting. Bolt it to the block using both bolts and remove excess silicone.
5. Cut notch for dipstick tube clearance.

