

# DA027

## ENGINEQUEST

(800) 426-8771

(702) 649-7776

(702) 649-6777 fax

[www.enginequest.com](http://www.enginequest.com)



August 2001

### Weld-On Opposite Side Dipstick Adaptors

convert pre-1980 Chevrolet Small Blocks to 1980 thru 1985

#### Follow these steps...

1. Place block on bench with the head gasket surface on the passenger side on bench.
2. Place opposite side dip on block with the dip hole approximately in line with the center of number 4 main bearing cap. Measure as shown in the diagram 1-1/16" from oil pan bolt hole to center line of opposite side dip.
3. Weld in place using cast iron electrode.
4. Final Step: Grind 1/2" wide relief in block for dipstick tube.

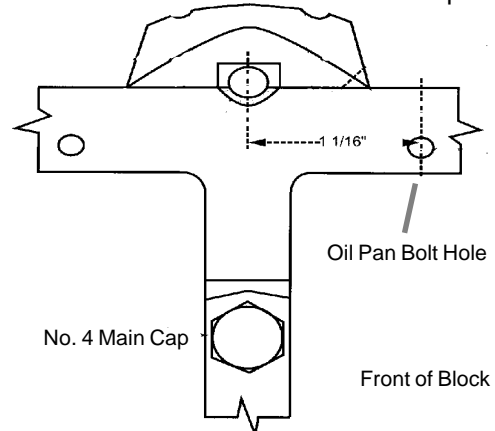

# DA027

## ENGINEQUEST

(800) 426-8771

(702) 649-7776

(702) 649-6777 fax

[www.enginequest.com](http://www.enginequest.com)

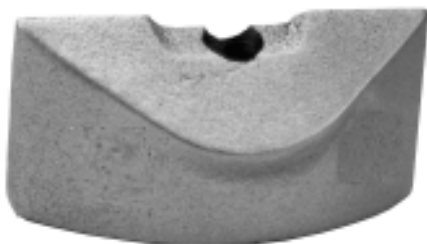

August 2001

### Weld-On Opposite Side Dipstick Adaptors

convert pre-1980 Chevrolet Small Blocks to 1980 thru 1985

#### Follow these steps...

1. Place block on bench with the head gasket surface on the passenger side on bench.
2. Place opposite side dip on block with the dip hole approximately in line with the center of number 4 main bearing cap. Measure as shown in the diagram 1-1/16" from oil pan bolt hole to center line of opposite side dip.
3. Weld in place using cast iron electrode.
4. Final Step: Grind 1/2" wide relief in block for dipstick tube.

